

AQ1501150

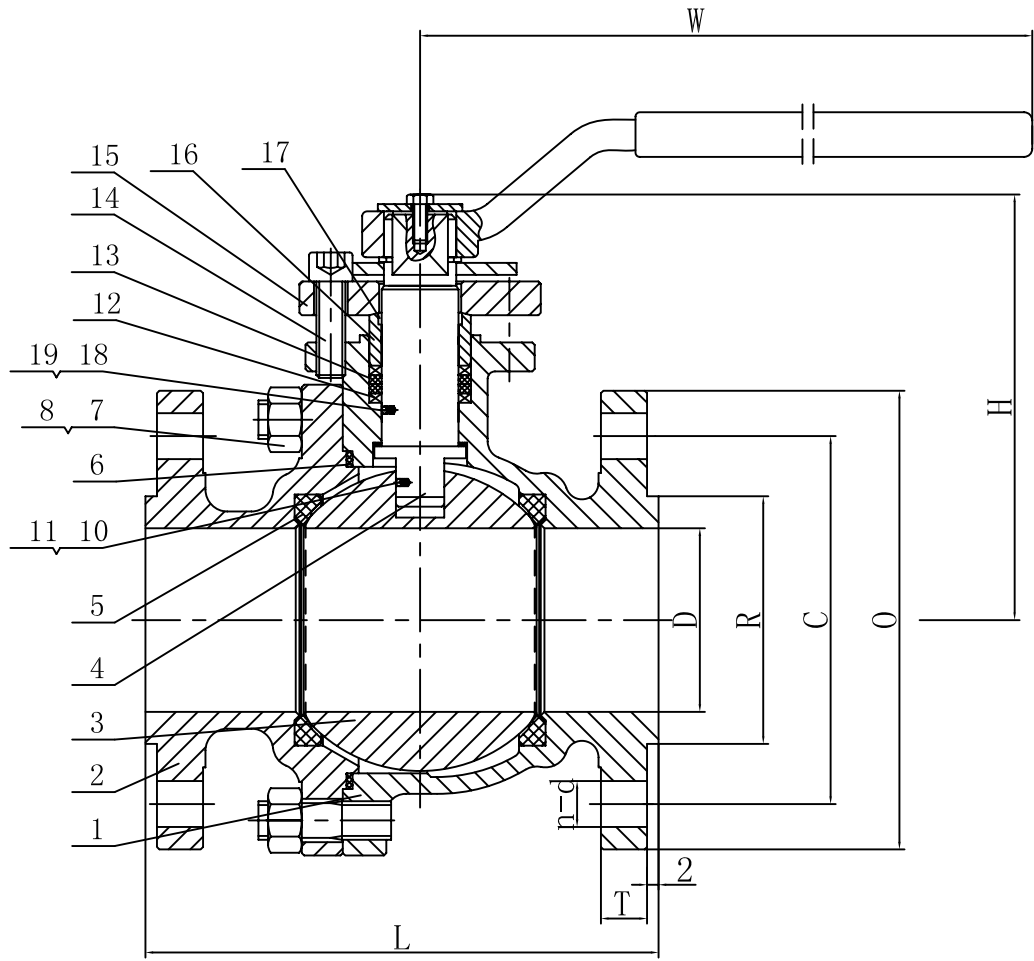
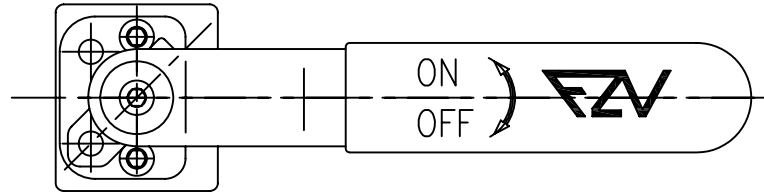

ITEM	NAME(English)	MATERIAL
1	BODY	A216 WCB
2	BONNET	A216 WCB
3	BALL	A182 F316
4	STEM	A182 F316
5	SEAT	RPTFE
6	F. S WASHER	316+graphite
7	NUT	A194 2H
8	BOLT	A193 B7
10	SMALL STEEL BALL	A276 316
11	ANTISTATIC SPRING	A276 316
12	F. S WASHER	graphite+316
13	F. S WASHER	graphite
14	INNER HEXAGON SCREW	A193 B7
15	GLAND FLANGE	A216 WCB
16	GLAND RING	A276 316
17	BEARING	RPTFE
18	SMALL STEEL BALL	A276 316
19	ANTISTATIC SPRING	A276 316

DESIGN STD.	API 6D	END CONN.	RF
PRES. & TEMP.	ASME B16.34	PRES. TEST	API 598
FACE TO FACE	ASME B16.10	END DIME.	ASME B16.5
MARKING	MSS SP-25	F. S. DESIGN	API 607
PAINTING		SPECIAL	

CLIENT INFORMATION	
REF.	
ORDER	
PROJECT	
CLIENT	Industrial & Designer Valves
APPROVE	

**FZV**

ADD: WENZHOU CHINA  
 HTTP://WWW.CHINA-FZV.COM  
 TEL: 0577-67356851  
 FAX: 0577-67358449

UNIT: mm

ITEM	SIZE	L	D	R	C	O	n-d	T	W	H
13	1/2"	108	13	34.9	60.3	90	4-16	8	150	63
14	3/4"	117	19	42.9	69.9	100	4-16	8.9	150	67
15	1"	127	25	50.8	79.4	110	4-16	9.6	150	75

REV. NO.	MARKING	SIGNATURE	DATE
DESIGN	LJJ	JOB NO.	
APPROVE	ZMJ	FZV NO.	AQ1501150
DATE	2015-2-28	PAGE	

TYPE:  
BALL VALVE  
CLASS 150