

AQ1501150

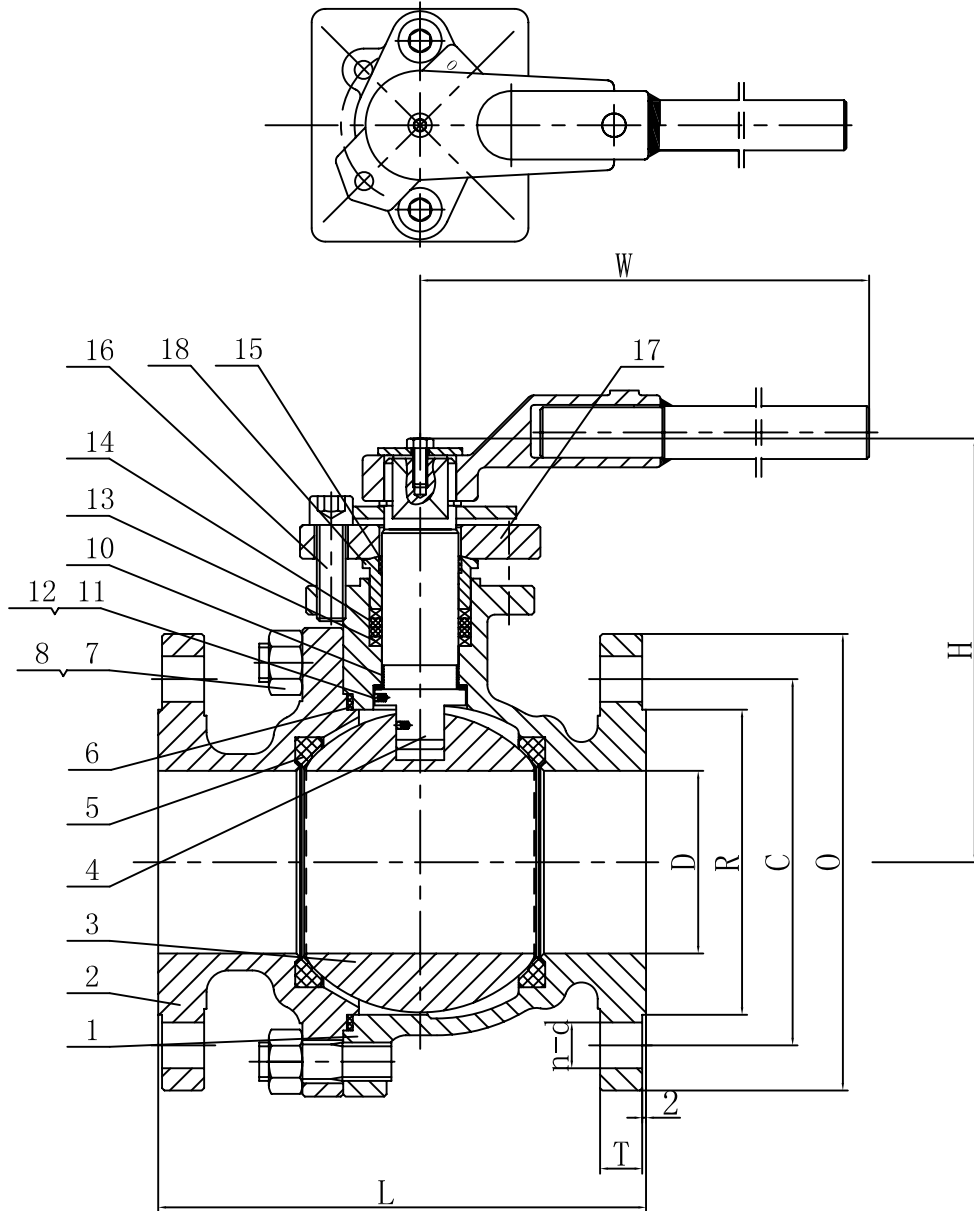

ITEM	NAME (English)	MATERIAL
1	BODY	A351 CF8M
2	BONNET	A351 CF8M
3	BALL	A182 F316
4	STEM	A182 F316
5	SEAT	RPTFE
6	F. S WASHER	316+graphite
7	NUT	A194 8
8	BOLT	A193 B8
10	BEARING	RPTFE
11	SMALL STEEL BALL	A276 316
12	ANTISTATIC SPRING	A276 316
13	F. S WASHER	graphite+316
14	F. S WASHER	graphite
15	BEARING	RPTFE
16	INNER HEXAGON SCREW	A193 B8
17	GLAND FLANGE	A351 CF8M
18	GLAND RING	A276 316

DESIGN STD.	API 6D	END CONN.	RF
PRES. & TEMP.	ASME B16.34	PRES. TEST	API 598
FACE TO FACE	ASME B16.10	END DIME.	ASME B16.5
MARKING	MSS SP-25	F. S. DESIGN	API 607
PAINTING		SPECIAL	

CLIENT INFORMATION			
REF.			
ORDER			
PROJECT			
CLIENT	Industrial & Designer Valves		
APPROVE			



ADD: WENZHOU CHINA  
 HTTP:WWW.China-FZV.COM  
 TEL:0577-67356851  
 FAX:0577-67358449

REV. NO.	MARKING	SIGNATURE	DATE
DESIGN	LJJ	JOB NO.	
APPROVE	ZMJ	FZV NO.	AQ1501150
DATE	2015-2-28	PAGE	

TYPE:  
 BALL VALVE  
 CLASS 150

UNIT: mm

ITEM	SIZE	L	D	R	C	O	n-d	T	W	H
25	2"	178	50	92.1	120.7	150	4-19	14.3	300	135