

AQ1410243

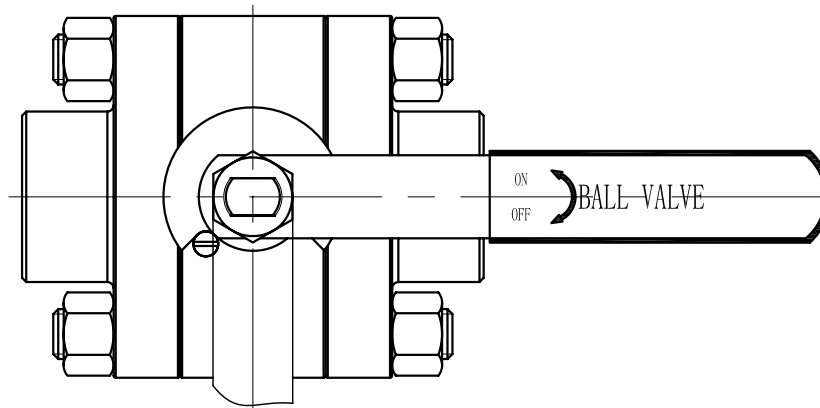
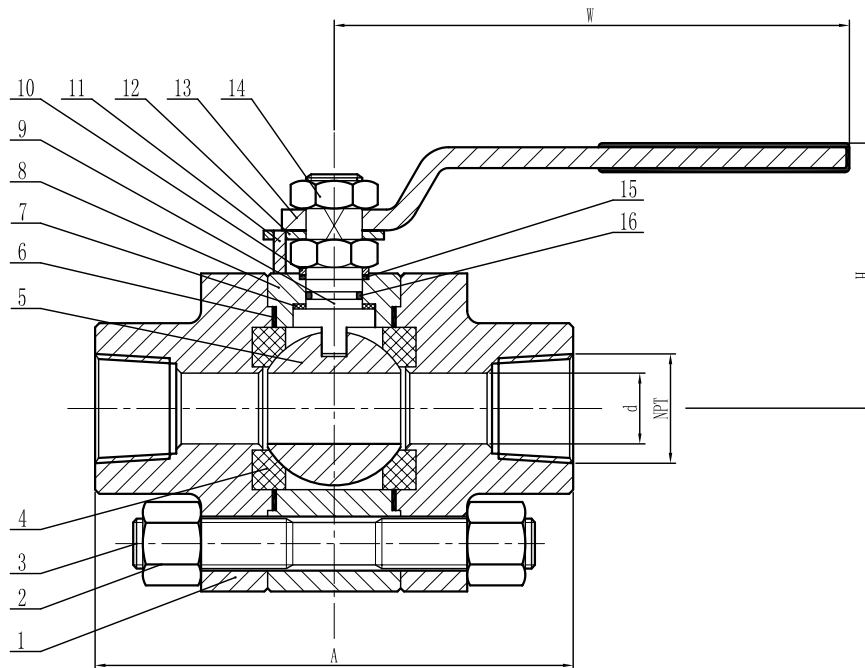

NO	PART NAME	MATERIAL	REMARKS
1	BONNET	A182 F316	
2	NUT	A194 GR.8	
3	STUD BOLTS	A193 GR.B8	
4	SEAT RING	POM	
5	BALL	A182 F316	
6	BODY GASKET	GRAPHITE +SS316	
7	THRUST WASHER	PTFE	
8	BODY	A182 F316	
9	STEM	A182 F316	
10	GLAND	STAINLESS STEEL	
11	POSITIONING PIN	STAINLESS STEEL	
12	POSITIONING PLATE	STAINLESS STEEL	
13	LEVER	A3+Cr+PLASTIC	
14	STEM NUT	STAINLESS STEEL	
15	PACKING	GRAPHITE	
16	STEM "O" RING	VITON	

DESIGN STD.	ASME B16.34	END CONN.	NPT
PRES. & TEMP.	ASME B16.34	PRES. TEST	API 6D
FACE TO FACE	FZV	END DIM.	ANSI B1.20.1
MARKING	MSS SP-25	F.S. DESIGN	API 607
PAINTING	FZV	SPECIAL	

CLIENT INFORMATION			
REF.			
ORDER			
PROJECT			
CLIENT	Industrial & Designer Valves		
APPROVE			

FZV

ADD: WENZHOU CHINA
 HTTP:WWW.China-FZV.COM
 TEL:0577-67356851
 FAX:0577-67358449

ITEM	CLASS	SIZE	A	d	NPT	H	W
4	800LB	1/2"	92	14	1/2"	70	130
5	800LB	3/4"	111	19	3/4"	75	160
6	800LB	1"	127	25	1"	95	220

REV. NO.	MARKING	SIGNATURE	DATE
DESIGN	LJW	JOB NO.	
APPROVE		FZV NO.	AQ1410243
DATE	2014-11-14	PAGE	

TYPE:
 BALL VALVE
 CLASS 800LB